

TFA

LM6A

6km Laser Rangefinder Module

With single-time ranging and
continuous ranging function





PRODUCT FEATURES

Integrated configuration design and front end face multi-point sealing installation, strong anti-imbalance ability, high durability, long working life, eye safety;

Using non-thermal receiving optical design technology, with good optical noise suppression ability, near distance ranging performance and high and low temperature optical performance

The internal interface of the circuit adopts the welding wire direct connection process, which is firm and reliable, which can avoid the short circuit or poor contact caused by the loosening, oxidation and water vapor of the connector, and improve the reliability and life of the product.

PERFORMANCE

PRODUCT PERFORMANCE INDEX

Item	Index	
Model	LM6A	
Operating wavelength	1535nm \pm 10nm	
Eye-Safe	Class 1 (IEC 60825-1)	
Receiving Aperture	ϕ 25mm	
Ranging range	30-10000m	
Ranging capability	10000m	Max Ranging(Typical Large targets)
	8000m	Large target, Reflectivity: 60 %,visibility \geq 25km
	6000m	Visibility \geq 25km, target with 0.3 reflectivity for 2.3m \times 2.3m target
	3000m	1 \times 1 m target,Reflectivity: 10%,Visibility \geq 25km
Communication Interface	RS422	
Humidity	<80%	
Ranging accuracy	\pm 1m	
Accuracy rate	\geq 98%	
Divergence angle	\leq 0.5mrad	
Ranging frequency	1~10hz	
Continuous ranging time	\geq 30min	
Non-parallelism of the laser optical axis to the mounting reference	<0.3mrad	
Size	\leq 70mm \times 48mm \times 32mm	
Voltage	9-15V	
Power consumption	Standby:<1.5W; Rated:<4W; Peak:<7W	
Working temperature	-40°C~+60°C	
Storage temperature	-45°C~+70°C	
Weight	\leq 100g	

Function:

- 1: With single ranging and continuous ranging function
- 2: laser out of the number of times the report function
- 3: With multi-target ranging function

Structure installation interface

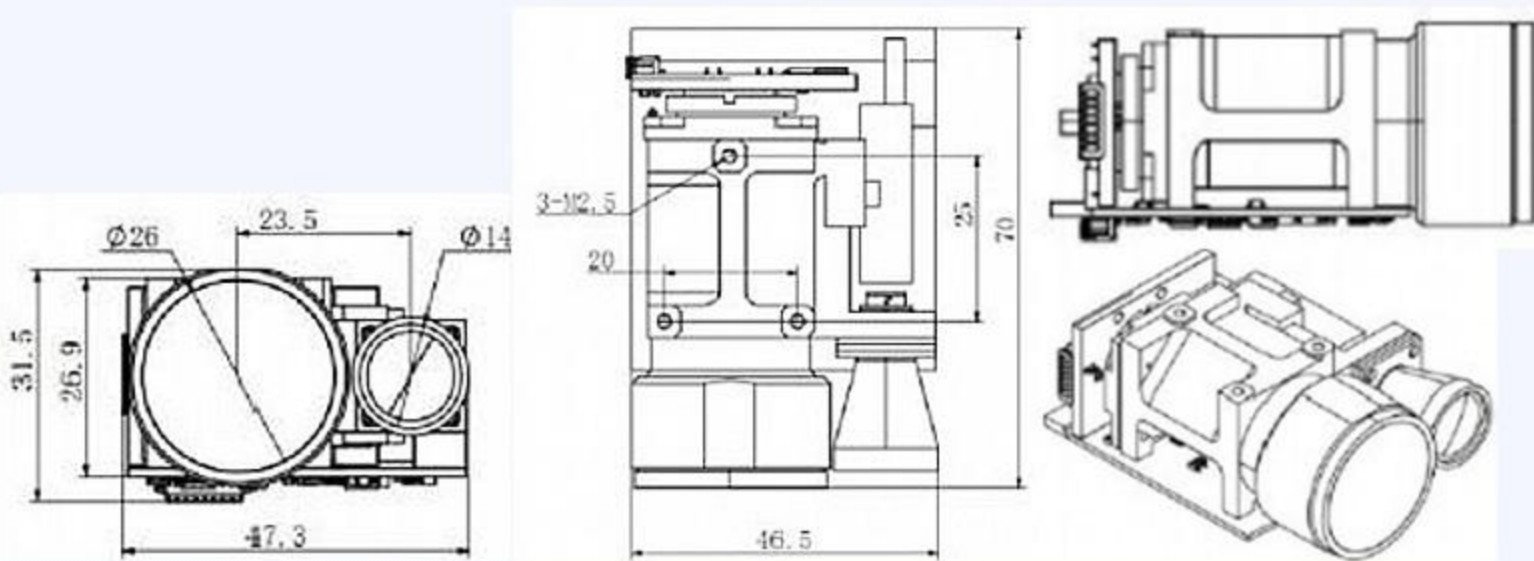

Electrical interface

- Communication interface: UART_TTL, RS422, RS232, one of the three options, see Annex 1 for protocol details;
- Use PHD-2 \times 5 connector, the interface definition is shown in the table.

Table 3 Electrical Interface Definition

Pin	Interface Type	Definition	Remarks
1	Power Supply	+12V power supply	
2		+12V Power Ground	
3	Communication	RS422-Y(T+)	In respect of this machine
4		RS422-B(R-)	
5		RS422-Z(T-)	
6		RS422-A(R+)	
7	Communication Ground	GND	
8	Communication	UART_TX, RS232_TXD	
9		UART_RX, RS232_RXD	
10	Communication Ground	GND	

Position of pin 1 of connector

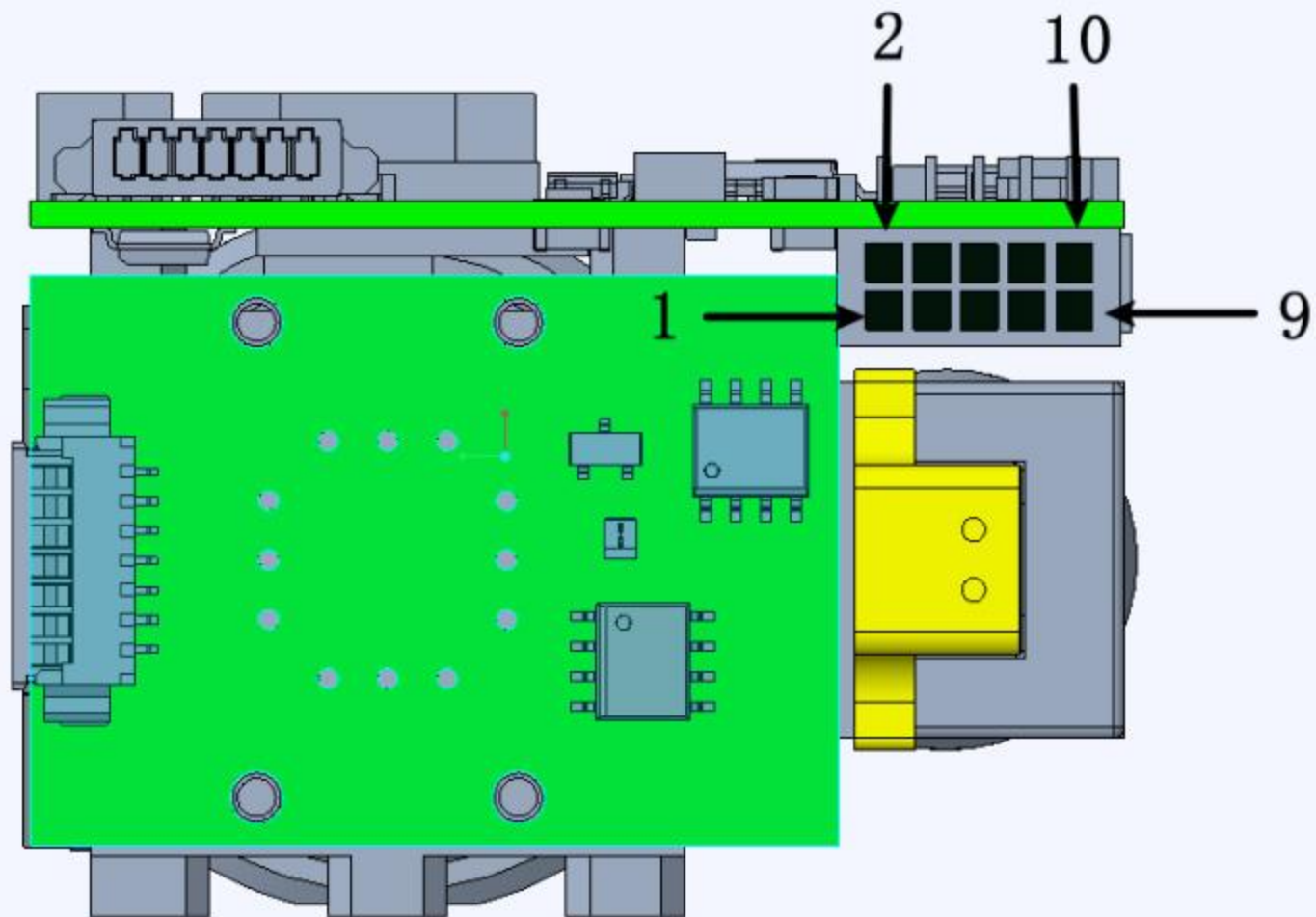
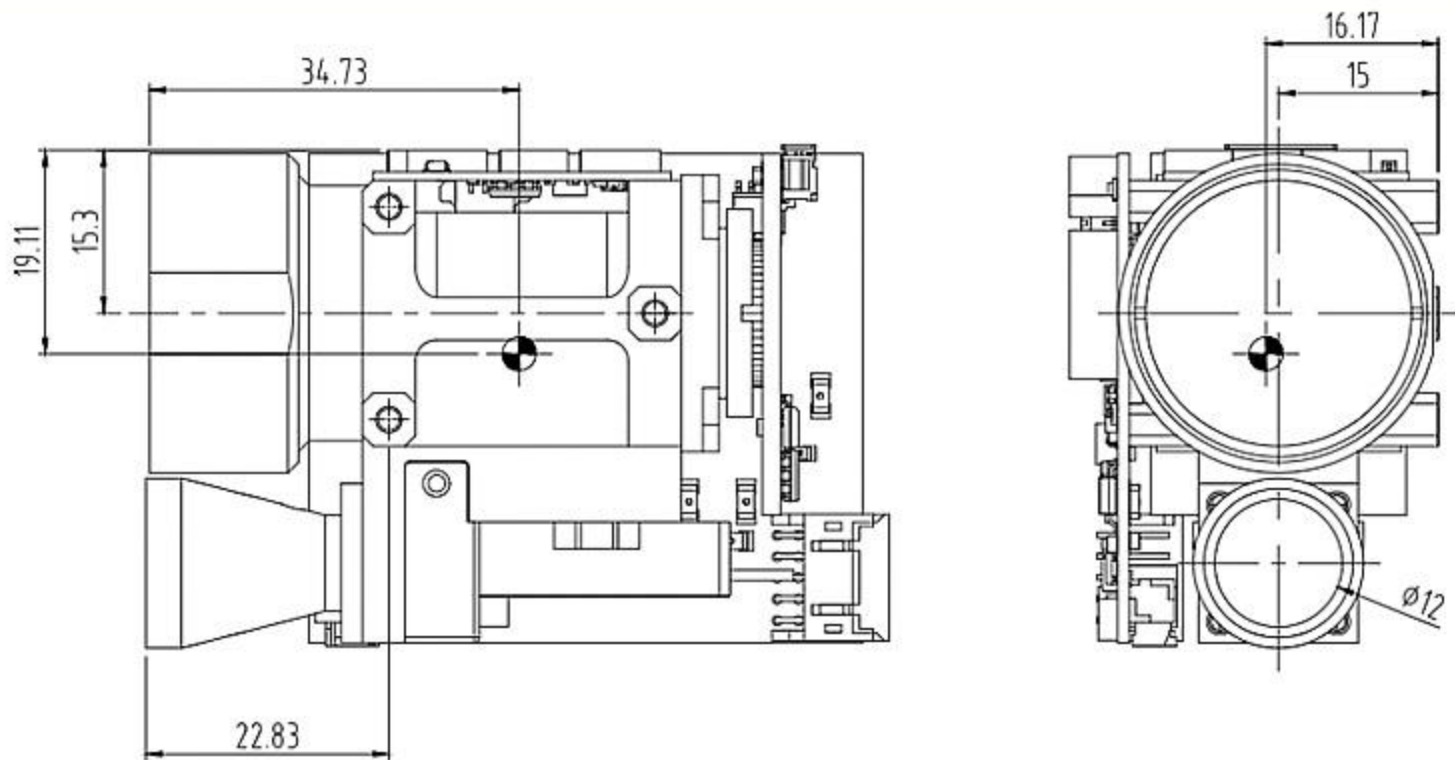

Diagram of Center of Gravity Installation



COMMUNICATION PROTOCOLS

Communication rate and format

Format Standards	115200 (factory), N, 8,1, multi-byte data starting high.
Data type	char one byte, int two bytes, long four bytes; signed (default), unsigned.

Basic packet format

① Starting character	② Data length	③ Data content	④ Sum check
0xEB	0x90	unsigned char	unsigned char
“④Sum check” refers to the sum of all contents except the checksum, taking the lower 8 bits.			
Command data and response data are located in “③Data content”.			

Command data format

Target device code	Command Code	Additional data of a certain length
unsigned char	unsigned char	unsigned char[]
The time interval between characters should be $\leq 20\text{ms}$.		
Normal command codes must not use 0xFF.		

Response data format

Self device code	Response code	Additional data of a certain length
unsigned char	unsigned char	unsigned char[]
The device should provide a response within 1 second, and the time interval between characters should be $\leq 20\text{ms}$.		
All commands on the bus serial port are responsive.		

Device code

Device Name	Device Code
LRF	0x03

Response Code

Type	Response Code	Additional Data	Meaning	Description
Normal response	Command code	See attachment	Successful execution	Command was processed normally, see device command for additional data.

LASER SELF-TEST

Sent to the laser rangefinder

bytes	0	1	2	3	4	5
Description	0xEB	0x90	②data length (2)	0x03	0x01	Check_sum

The laser rangefinder returns

bytes	0	1	2	3	4	5	6	7	8	9
Description	0xEB	0x90	②data length (12)	0x03	0x01	<u>Selfcheck</u>	standby	standby	standby	standby
10	11	12	13	14	15					
standby	standby	standby	standby	standby	standby					

Selfcheck define

position	D7	D6	D5	D4	D3	D2	D1	D0
Description	System status: 0: Normal 1: Abnormal					Temperature alarm: 0: Normal 1: Alarm	Bias voltage fault: 0: Normal 1: Fault	Counter malfunction: 0: Normal 1: Fault

SINGLE RANGING

Send to the LRF

Bytes	0	1	2	3	4	5
Description	0xEB	0x90	②data length (2)	0x03	0x02	Check_sum

STOP RANGING

Send to the LRF

Bytes	0	1	2	3	4	5
Description	0xEB	0x90	②data length (2)	0x03	0x04	Check_sum

RETURN DISTANCE

LRF single ranging and auto-ranging return automatically by ranging frequency:

Bytes	0	1	2	3	4	5	6	7	8	9
Description	0xEB	0x90	② data length (12)	0x03	Single ranging: 0x02 Automatic ranging: 0x03 Standby: 0x00	status	Ranging value 1 integer high 8 bits	Ranging value 1 integer lower 8 bits	Ranging value 1 decimal section	Ranging value 2 integer high 8 digits
10	11	12	13	14	15					
Ranging value 2 integer lower 8 bits	Ranging value 2 decimal places	Ranging value 3 integer high 8 digits	Ranging value 3 integer lower 8 bits	Ranging value 3 decimal sections	Check_sum					

Note: The range value has 2 decimal places

Status define

position	D7	D6	D5	D4	D3	D2	D1	D0
Description	System status: 0: Normal 1: Abnormal	Front discharge power switch: 0: Close 1: Enable	LD power switch: 0: Close 1: Enable	Bias switch: 0: off 1: On	Working status: 0: Stop 1: Working	Echostate: 0: noecho 1: Echo	Main wave status: 0: without main wave 1: with main wave	Temperature alarm: 0: no alarm 1: alarm

SETTING THE FREQUENCY

Send to LRF

Bytes	0	1	2	3	4	5	6
Description	0xEB	0x90	② data length (3)	0x03	0x05	1-5:1-5Hz	Check_sum

Setting parameters LRF return

Bytes	0	1	2	3	4	5	6	7	8	9
Description	0xEB	0x90	② data length (12)	0x03	0x05: Set frequency 0x08: Query set value	standby	standby	standby	standby	standby
10	11	12	13	14	15	16	17	18	19	20
standby	Ranging frequency 1-5:1-5Hz	Major version number	Secondary version number	Maintenance version number	Check_sum					

QUERY SETTING VALUE

Send to laser rangefinder

Bytes	0	1	2	3	4	5
Description	0xEB	0x90	② data length (2)	0x03	0x08	Check_sum

LRF return:
Same as setup parameters

NUMBER OF TIMES QUERY THE ACCUMULATED NUMBER OF LASER OUT

Send to the laser rangefinder

Bytes	0	1	2	3	4	5
Description	0xEB	0x90	② data length (2)	0x03	0x07	Check_sum

LRF returns

Bytes	0	1	2	3	4	5	6	7	8	9
Description	0xEB	0x90	② data length (12)	0x03	0x07	Cumulative count D31-D2 4	Cumulative count D23-D1 6	Cumulative count D15-D8	Cumulative count D7-D0	standby
10	11	12	13	14	15	16	17	18	19	20
standby	standby	standby	standby	standby	Check_sum					

When working, the LRF returns the distance and status to the host computer automatically according to the ranging frequency, and when in standby, the LRF does not return the number.

PRODUCT DISPLAY





